

# Novo™ Series: Model 300

## Selective Soldering with Compact Footprint and Exceptional Value

### Features and Benefits

- Standalone platform idea for prototype, cell manufacturing or small batch production requirements
- Entry level selective soldering with compact footprint requiring less than 1.1 square meters of factory floor space
- Full titanium solder pot compatible with all solder alloys plus easy tool-free maintenance
- Modular platform design allows options to be added as application needs change
- Entry level selective soldering system with capability to solder printed circuit boards at the same speed as larger or expensive machines

Designed for a wide variety of selective soldering applications, the Novo™ 300 offers exceptional value with superior process capabilities and is ideal for prototype, small batch production or cell manufacturing. The Novo™ 300 has many unique features, including drop-jet fluxing, IR preheating and selective soldering with fast and easy programming and machine setup.

**Versatility.** With its compact form, single drop-jet fluxer and all titanium solder pot, the Novo™ 300 is a versatile selective soldering platform and has a soldering area of 300 x 300 mm. The Novo™ 300 can also process printed circuit boards as large as 500 x 300 mm (19.6 x 11.8 in.).

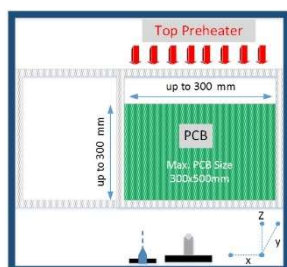

Novo™ 300 flux, preheat and soldering configuration



**Value.** With a reputation for innovation, comprehensive process solutions from Nordson SELECT ensure a maximum return on investment and low cost of ownership. From initial process development through full-scale production, you are supported by our experienced worldwide engineering, applications development and technical service network.

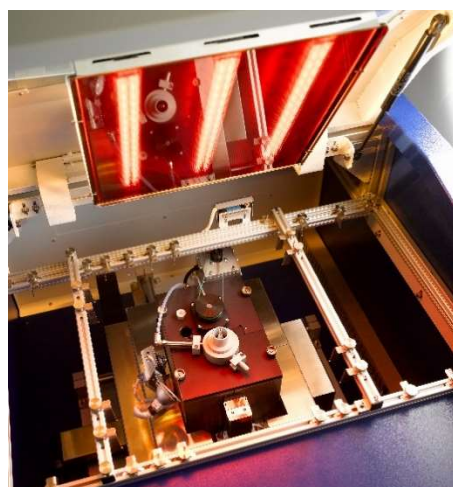

Novo™ 300 compact soldering platform

# Specifications: Novo™ 300

## Motion System

Z accuracy	±50 µm (0.002 in.)
Z repeatability <sup>(1)</sup> :	±50 µm (0.002 in.), 3 sigma
Z velocity:	0.05 m/s peak (2 in./s)
X-Y accuracy	±50 µm (0.002 in.)
X-Y repeatability <sup>(1)</sup> :	±50 µm (0.002 in.), 3 sigma
X-Y velocity:	0.2 m/s peak (8 in./s)

## Computer

PC with Windows® operating system

## Software

PhotoScan “point-and-click” programming editor and machine control software

## Solder Pot Capacity and Weight

Capacity <sup>(2)</sup>:     Approx. 12.0 kg (26.4 lbs.)

## Solderable Area (X-Y)

Max. 300 x 300 mm (11.8 x 11.8 in.)

## Board Holder Capability

Max. board size <sup>(3)</sup>:     500 x 300 mm (19.6 x 11.8 in.)

## Board Clearance

Max. overboard clearance: 120 mm (4.7 in.)

Max. underboard clearance: 40 mm (1.5 in.)

## Facilities Requirements

System footprint: 931 x 1235 mm (36.6 x 48.6 in.)

Compressed air: None required

Power (mains) <sup>(4)</sup>: Power supply accommodates 1 phase, 230VAC, 50-60 Hz, 2 kW, 13 A without preheater, or 3 phase, 400VAC, 50-60 Hz, 10 kW, 16 A with preheater

Nitrogen: 99.99% (4.0) pure, 4-6 bar, 1.3 m<sup>3</sup>/hour

Ventilation: Rear 150 m<sup>3</sup>/hour, 100 mm (4.0 in.) dia. duct

System weight <sup>(5, 6)</sup>:     350 kg (770 lbs.)

- (1) Repeatability is measured at full rated system speed.
- (2) Solder capacity and total weight of solder pot and pump assembly varies depending on solder alloy.
- (3) Contact factory regarding smaller or larger boards/carriers.
- (4) Electrical power varies depending on configuration.
- (5) System weight varies depending on configuration.
- (6) Configuration dependent. Other configurations may be available. Contact Nordson SELECT.

## Standard Features

MicroDrop drop-jet fluxer

Nitrogen preheating

All titanium solder pot and pump assembly

Quick change magnetically coupled solder nozzle

PhotoScan editor and machine control software

- Easy “point-and-click” programming
- Remote machine control
- Remote machine maintenance
- Network and FIS capability

TFT monitor

## Optional Features

Solder frame for printed circuit boards

Topside infrared preheating

Process viewing camera

Automatic solder level sensing system

Wave height control sensing system

Automatic solder nozzle cleaning system

Flux level monitoring with information display

Data logging system with traceability of all process parameters

Windows is a registered trademark of Microsoft Corporation in the United States and other countries.

## Standards Compliance

SMEMA, CE

**Additional options may be available: contact Nordson SELECT for further information.**

Dimensions are in millimeters

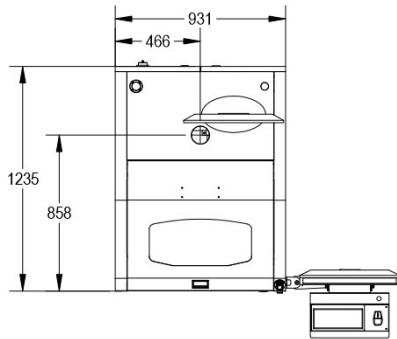

Top View (mm)

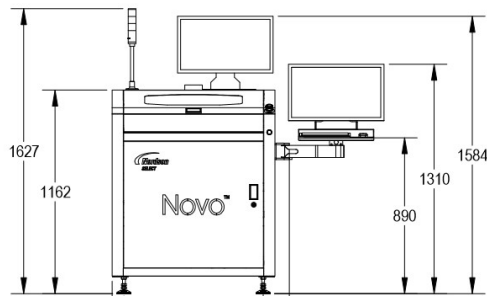

Front View (mm)

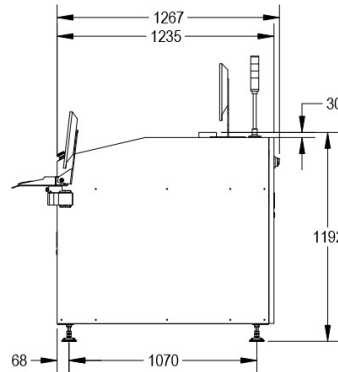

Side View (mm)

**For more information, speak  
with your local representative  
or contact your regional office.**

**[Nordsonselect.com](http://Nordsonselect.com)**

**North America**

*Headquarters*

Spokane Valley, WA, USA

+1.509.924.4898

[info@nordsonselect.com](mailto:info@nordsonselect.com)

**China**

Email:

[info@nordsonselect.com](mailto:info@nordsonselect.com)

Shanghai

+86.21.3866.9166

Beijing

+86.10. 8453.6388

Guangzhou

+86.20.8554.9996

**Europe**

Maastricht, Netherlands

+31. 43.352.4466

[info@nordsonselect.com](mailto:info@nordsonselect.com)

**Japan**

Tokyo

+81.3.5762.2801

[Info@nordsonselect.com](mailto:Info@nordsonselect.com)

**Korea**

Seoul

+82.31.765.8337

[info@nordsonselect.com](mailto:info@nordsonselect.com)

**India**

Chennai

+91. 44.4353.9024

[info@nordsonselect.com](mailto:info@nordsonselect.com)

**S.E. Asia/Australia**

Singapore

+65.6796.9514

[info@nordsonselect.com](mailto:info@nordsonselect.com)

**Taiwan**

+886.229.02.1860

[info@nordsonselect.com](mailto:info@nordsonselect.com)

**Nordson SELECT, Inc.**

**Germany Office**

**+49 (0) 7273 949466 0 Phone**

**[info@nordsonselect.com](mailto:info@nordsonselect.com) Email**

**Perläckerstraße 11**

**76767 Hagenbach**

**Germany**

**[www.nordsonselect.com](http://www.nordsonselect.com)**

**Published 2017-15-08**